



RN-1278C Remote Tubular Nugget Ice Machine

Models

RN-1278C



RN-1278C Remote Nugget Ice Machine - 115V



RCU Condensing Unit - 208-230V



RN-1278C Remote Nugget Ice Machine on B-570 Bin



RN-1278C Remote Nugget Ice Machine on Servend SV-250 Dispenser

Standard Features

QuietQube® Series Remote System consists of a remote condensing unit, interconnecting refrigerant lines, ice machine head section, and ice storage unit— whether storage bin, countertop or floor-standing dispenser. All ordered separately. QuietQube ice machine with RCU condensing unit is designed as a Manitowoc system and not for use with any other ice machine or remote condenser brand.

- Up to 1,100 lbs. (499 kgs) daily ice production.
- Only 22" (55.88 cm) wide.
- Evaporator is designed for maximum quality and operating life.
- Quiet operation eliminates most noise from the refrigeration system. Promotes a relaxing atmosphere.
- Ice machine is lighter in weight and 115 volt simplifies installation.
- Stainless steel exterior has a clean and modern look to enhance the display in any self-serve environment.

COMMERCIAL WARRANTY		
ICE MAKER	COMPRESSOR	
3	2	5
YEAR PARTS	YEAR LABOR	YEAR PARTS 2 YEAR LABOR

Ice Shape

- Tubular Nugget Ice provides a softer, chewable texture while still providing maximum cooling effect.
- 5/8" (1.59 cm) diameter cylindrical-shaped nugget with average length of approximately 1" (2.54 cm).





RN-1278C Ice Machine

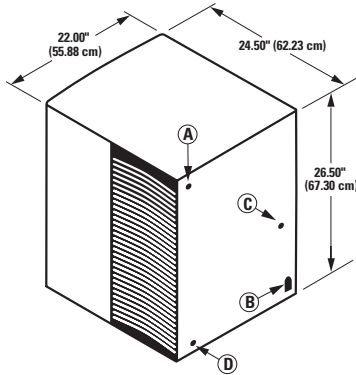

Shipping Weight: 201 lbs. / 91 kgs

- Ⓐ 3/8" F.P.T. Ice Making Water Inlet
- Ⓑ Refrigerant Lines
- Ⓒ Electrical Entrance
- Ⓓ 3/4" M.P.T. Drain Fitting

Dispenser Note - Verify with the dispenser manufacturer that the correct agitator and deflector kit for nugget ice dispensing is included with your dispenser purchase.

Ice Machine Electric

115/60/1 ice machines are factory pre-wired with a 7' (2m) power cord and NEMA 5-15 right angle plug configuration.

Total Amps: 6.0

Max. fuse size: 15 amps

The ice machine and condensing unit are powered independently of each other.

Specifications

Refrigerant: R404A

Operating Limits:

- Ambient Temperature Range: 50°-100°F (14.4°-37.8°C)
- Water Temperature Range: 45°-90°F (7.2°-32.2°C)
- Water Pressure Ice Maker Water In: Min. 20 psi (137.9 kPA) Max. 70 psi (483 kPA)

RCU-1275 Condensing Unit

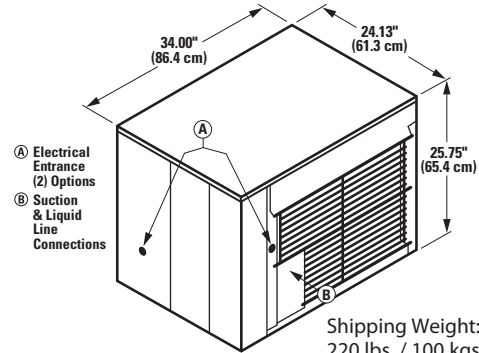

Shipping Weight: 220 lbs. / 100 kgs

Condensing Unit Electric

208-230/60/1 standard. 208-230/60/3 also available. **Note:** QuietCube ice machine is wired independent of condensing unit.

Min. circuit ampacity: 15 1ph 15 3ph

Max. fuse size: 15 1ph 15 3ph

BTU Per Hour: 14,400 (average)

Compressor: Nominal rating: 2 HP

Operating Limits:

Ambient Temperature Range: -20° to 120°F (-29° to 49°C)

Installation Information and Dimensions:

Maximum Line Length—100' (30.5 m)*

Maximum Vertical Rise*—35' (10.7 m) above ice machine.

Maximum Vertical Drop—15' (4.5 m) below ice machine.

*A rise over 20' (6 m) requires S-Trap Kit K-00172 - ordered separately

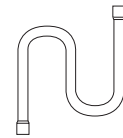

Remote Air-cooled Ice Machine

Model	Ice Shape	Ice Production 24 Hours		Power Usage kWh/100 lbs. @ 90°Air/70°F Water 32 Air/21C Water	Potable Water Usage/ 100 lbs. 45.4 kgs of Ice
		70°Air/ 50°F Water 21°Air/ 10°C Water	90°Air/ 70°F Water 32°Air/ 21°C Water		
RN-1278C	Tubular Nugget	1100 lbs.	962 lbs.	4.93	13.2 Gal.
		499 kgs	436 kgs		

Order ice storage bin separately. Will not accept AuCS accessory.

Standard Interconnecting Tubing

Model	Line Length		Weight	
	ft.	m	lbs.	kgs
RC-21	20	6	12	5
RC-31	30	9	20	9
RC-51	50	15	28	13